



**1992-UP CHEVY / GMC DUALY BOX INSTALLATION SHEET
PART #11513**

Congratulations on your purchase of a high quality PUTCO product. Should you need any application or technical assistance feel free to call us at:

1-800-247-3974

Monday-Friday 8:00 a.m.- 5:00 p.m. (Central Standard Time)

Contact your PUTCO dealer for other quality accessories.

PUTCO Inc. - 216 West First Street - Story City, Iowa 50248

PLEASE READ ALL INSTRUCTIONS BEFORE BEGINNING INSTALLATION AND BE SURE TO CHECK TO SEE THAT ALL PARTS AND HARDWARE ARE INCLUDED.

Parts List

<u>Description</u>	<u>Qty</u>
Box boards	2
Flaps (#7494 & #7495)	2
2" Straight bracket (#548)	2
16-1/4" x 3" Flat bracket (#534)	4
14-3/4" Angle bracket (#553)	4
Bent angle (#511)	2
End caps (#7811)	2
1/4" x 1-1/4" SS Slot head screw (#726)	20
1/4" x 3/4" Hex head bolts (#730)	30
1/4" Hex nut (#790)	50
1/4" Lock washer (#780)	50
1/4" x 3/4" Self drill & tap screws (#701)	12
36" Vinyl Foam Tape (#695)	2

Tools Needed for Installation

Electric Drill
1/4" Drill Bit
3/8" Magnetic Drive Socket
3/8" Wrench
7/16" Wrench and Socket
Screwdriver
Vise grips
Level

NOTE: Remove the protective plastic coating from the running boards and mud flaps. Trim the black vinyl tape on the running boards, so that the tape edge is flush with the end of the running board. The steps and figures shown are for the passenger side installation.

Step 1: Form the mud flaps to conform to the wheel well opening. **(SEE FIGURE 1)** Then bolt the stainless steel mud flap to the rear of box board using 1/4" x 1-1/4" SS slot head screws, lock washers, and nuts. Now bolt an (#7811) end caps to the front of the box board, using two 1/4" x 1" screwdriver head bolts, lock washers, and nuts. **(SEE FIGURE 4 & 5)**

Step 2: Apply foam tape (#695) along back lip of box board. **(SEE FIGURE 2)**

Step 3: Using three C-clamps or vice grips, clamp the box board to the rocker panel, and the stainless steel mud flap to the wheel well flange. Make sure the box board is level.

Step 4: Drill three 1/4" holes through the rocker panel lip. Install 1/4" x 1" screwdriver head bolts, lock washers, and nuts. **(SEE FIGURE 2 & 3)**

Step 5: Bolt a 14-3/4" long angle brace (#553) to the braces located on the box board at 5-3/8" and 23-1/2" from the front of the box board, using hex head bolts, lock washers, and nuts. On the 14-3/4" angle brace (#553) located at 5-3/8" attach a 2" angle bracket (#548) to the end next to the frame. Make sure the box board and cab board line up, also that the box board is level outward from the vehicle. Now adjust the 2" angle bracket (#548) so that it is tight against the frame, it is optional to attach the 2" angle to the frame with hex head bolt, lock washer, and nut. **(SEE FIGURE 4)** Now bolt 3" X 16-1/4" flat brace (#534) to 14-3/4" angle braces (#533). **(SEE FIGURE 4)** Attach the other end of the (#534) flat brace to the vehicles underbody cross braces, then install the 1/4" x 3/4 hex head self drill and tap screws with a lock washer.

Step 6: Make sure the rear of the box board is level outward from the vehicle. Attach the bent flap brace to stainless steel mud flap. Install with a screwdriver head bolt, lock washer, and nut. Attach the other end to the inner fender brace bolt. **(SEE FIGURE 5)**

Note: PUTCO recommends applying a high quality automotive wax to maintain the original appearance on your new running boards.

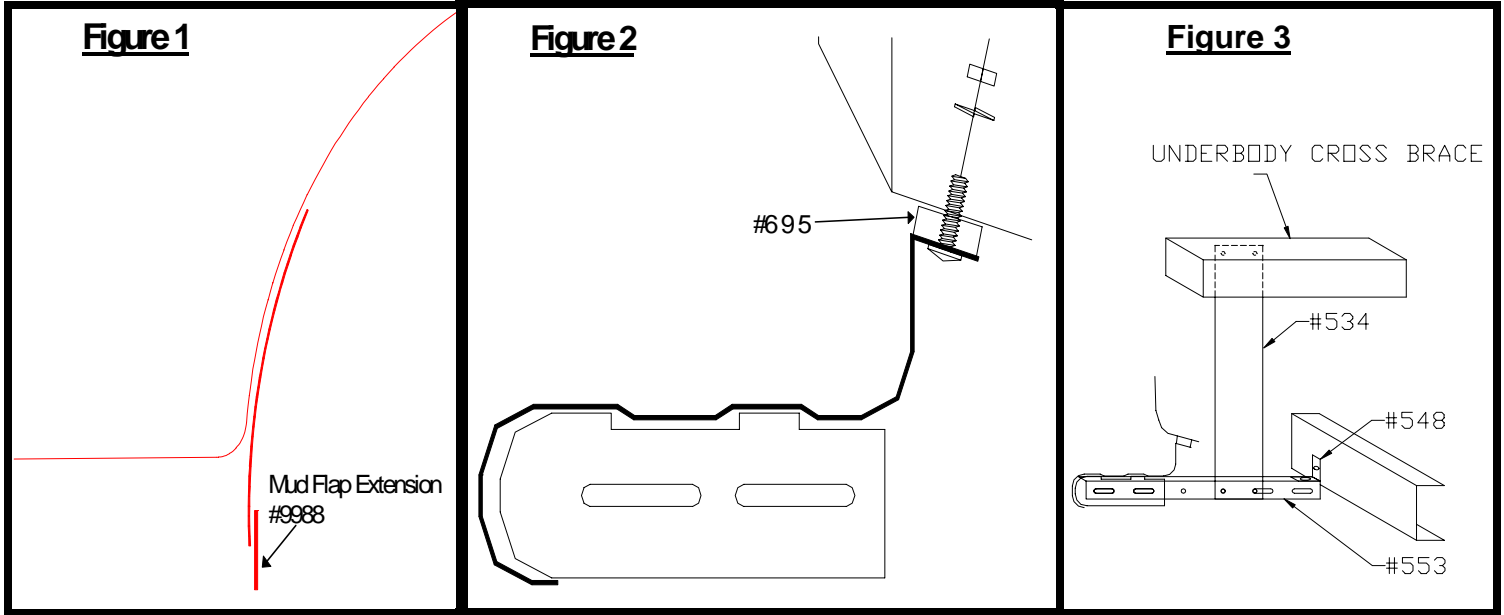

Figure 4

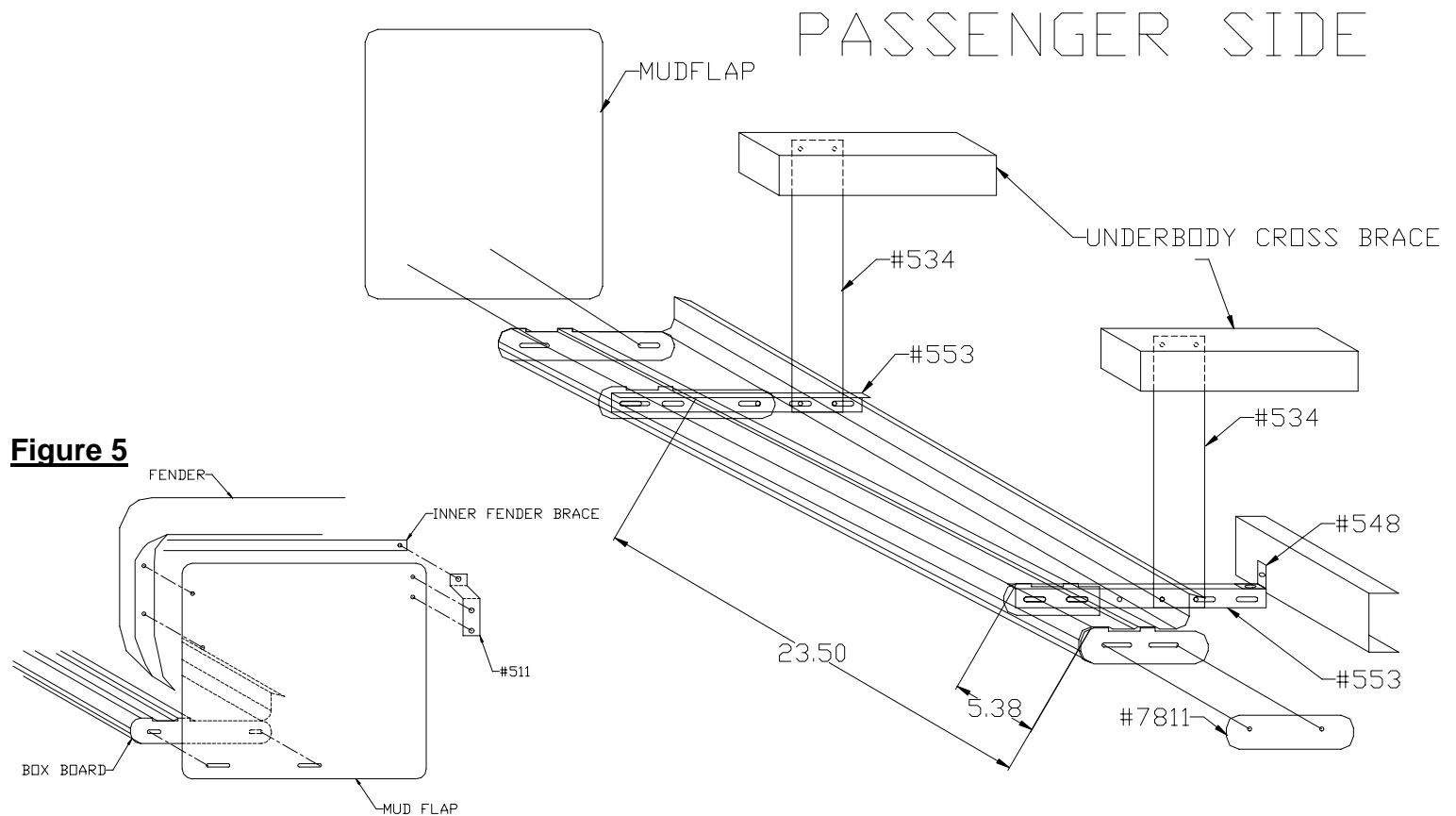

Figure 5

LIMITED WARRANTY

Putco guarantees its Stainless Steel and Aluminum products against defects in workmanship and material for as long as you own your vehicle. Black products have a 90 day warranty on the painted surface. Any defects resulting from faulty material or workmanship will be warranted by Putco and repaired or replaced at our discretion. Putco assumes no extra labor costs. Damages caused by freight carriers, improper installation, misuse, collision, or neglect will not be warranted by Putco.