



**1994-UP DODGE RAM INSTALLATION SHEET
PART #13502 (LONG BOX)**

Congratulations on your purchase of a high quality PUTCO product. Should you need any application or technical assistance feel free to call us at:
1-800-247-3974

Monday-Friday 8:00 a.m.- 5:00 p.m. (Central Standard Time)

Contact your PUTCO dealer for other quality accessories.

PUTCO Inc. - 216 West First Street - Story City, Iowa 50248

PLEASE READ ALL INSTRUCTIONS BEFORE BEGINNING INSTALLATION AND BE SURE TO CHECK TO SEE THAT ALL PARTS AND HARDWARE ARE INCLUDED.

Parts List	
Description	Qty
Box boards	2
Flaps (#7422 & #7423)	2
Flap extensions (#9988)	2
2" Angle bracket (#548)	2
18-1/2" Angle bracket (#554)	4
1/4" x 1-1/4" SS Slot head screw (#726)	20
1/4" x 3/4" Hex head bolts (#730)	30
1/4" Hex nut (#790)	50
1/4" Lock washer (#780)	50
1/4" x 3/4" Self drill & tap screws (#701)	12
18" Mini-Trim (#7820)	2
Endcaps(#7811)	2
27-1/2" Channel (#557)	2
9" Straight braces (#530)	4
Straight braces (#514)	4

Tools Needed for Installation
Electric Drill
1/4" Drill Bit
11/64" Drill Bit
3/8" Wrench
7/16" Wrench or Socket
Screwdriver
Level
Vise Grips

NOTE: Remove the protective plastic coating from the box boards and mud flaps. Trim the black vinyl tape on the running boards, so that the tape edge is flush with the end of the running board. The steps and figures shown are for the passenger side installation.

Step 1: Form the mud flaps to conform to the wheel well opening. **(SEE FIGURE 1)** Bolt the mud flap extensions **(#9988)** to the stainless steel mud flap and then to the front of the board using 1/4" x 1-1/4" SS slot head screws, lock washers, and nuts. Next apply mini-trim **(#7820)** only along the edge of the mud flap **(optional)**. **(SEE FIGURE 3)**

Step 2: Bolt an end cap **(#7811)** to the front of each running board with 1/4" x 1-1/4" SS slot head screws, lock washers, and nuts.

Step 3: Using 2 C-clamps or vice grips, clamp the 27-1/2" long channel **(#557)** to rocker panel, making sure the running board will line up with the cab board. Drill two 1/4" holes through the rocker panel. Install 1/4" x 3/4" hex head bolts, lock washers, and nuts. **(SEE FIGURE 2 & 3)**

Step 4: Clamp running board to channel and mud flap to wheel well flange. Make sure running board is as far forward as possible. Drill two 1/4" holes through the running board and channel. Install 1/4" x 1-1/4" SS slot head screws, lock washers, and nuts. **(SEE FIGURE 2)**

Step 5: Make sure running board is level outward from vehicle. Bolt the 18-1/2" angle brackets **(#554)** to the brace on the running board that is located at 6" and 18" from the front of the running board. **(SEE FIGURE 3)** Attach the 9" straight brace **(#530)** to the 18-1/2" angle bracket **(#554)**, the other end attaches to the box mount on the side of the frame bracket **(#554)** on the brace located at 6". **(SEE FIGURE 3)** Drill 11/16" holes through the side of the floor box beam and install 1/4" x 3/4" self drill and tap screws.

Step 6: Bolt a 9" straight brace **(#530)** to the 18-1/2" angle brace located at 18" from the front of the running board. **(SEE FIGURE 3)** Now attach the other end of the box mount on the side of the frame, by drilling two 1/4" holes in the side of the box mount.

Step 7: Make sure the board is level outward from the vehicle and level along the vehicle. Attach the mud flaps to the vehicle using three 1/4" self drill and tap screws per flap.

Note: PUTCO recommends applying a high quality automotive wax to maintain the original appearance on your new running boards.

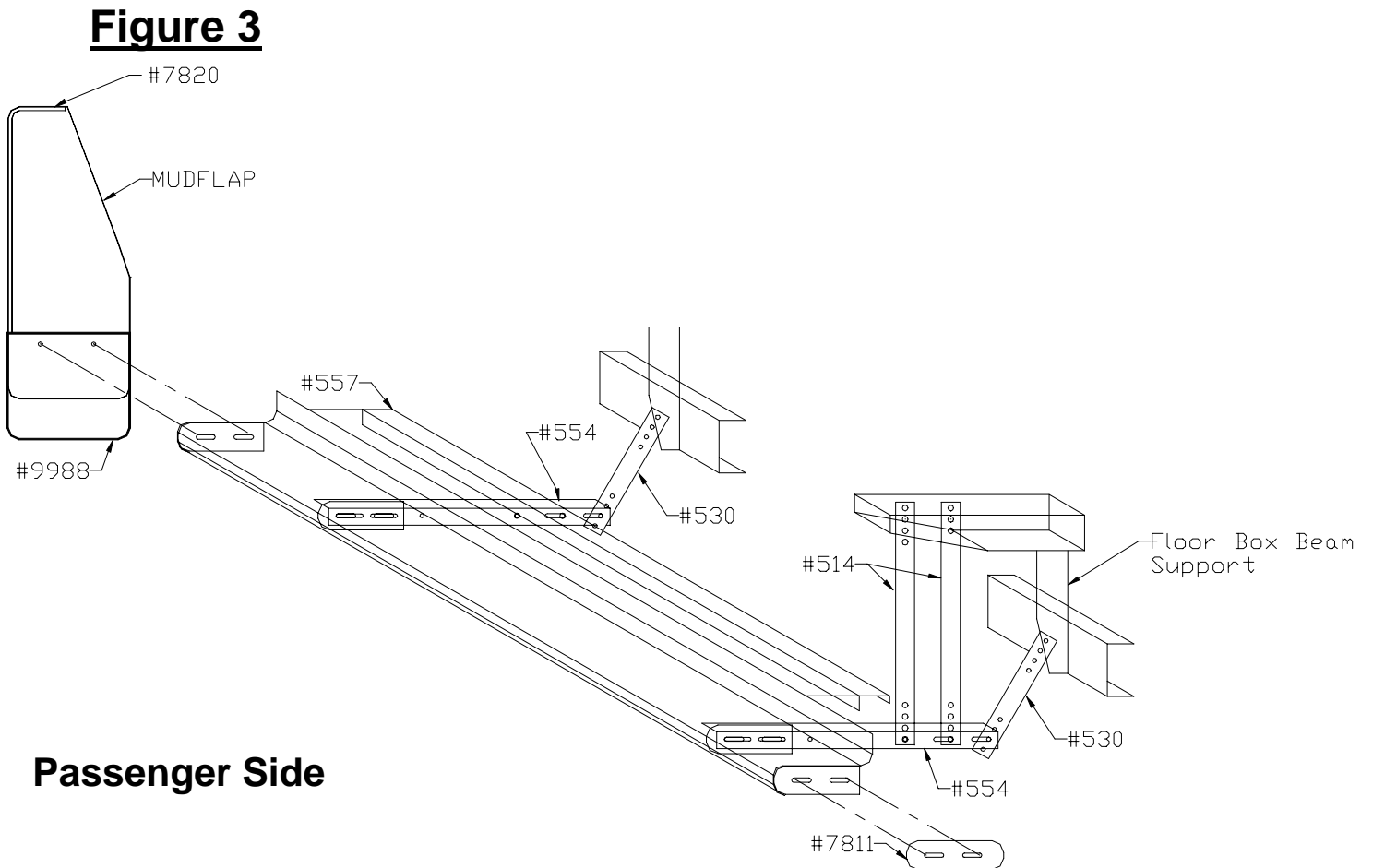
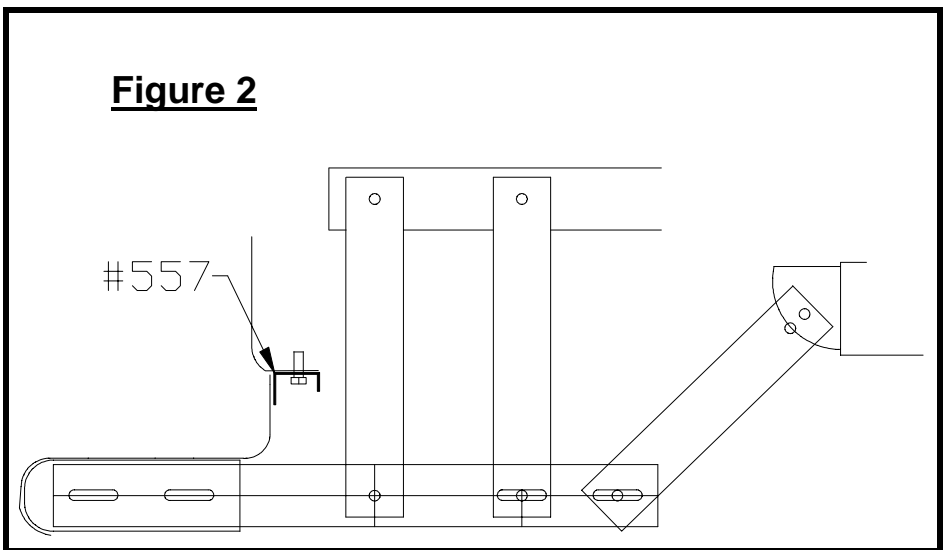
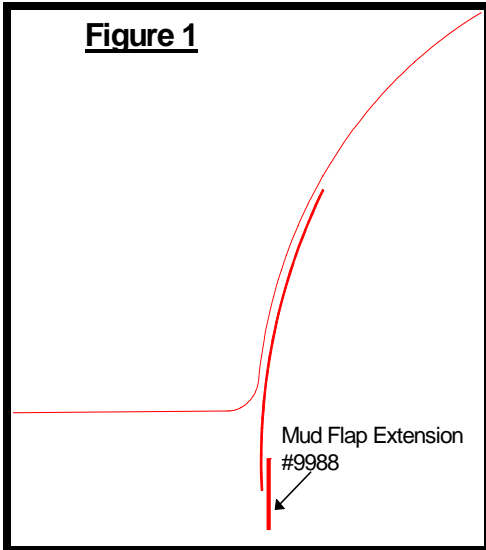

LIMITED WARRANTY

Putco guarantees its Stainless Steel and Aluminum products against defects in workmanship and material for as long as you own your vehicle. Black products have a 90 day warranty on the painted surface. Any defects resulting from faulty material or workmanship will be warranted by Putco and repaired or replaced at our discretion. Putco assumes no extra labor costs. Damages caused by freight carriers, improper installation, misuse, collision, or neglect will not be warranted by Putco.