



**2003-Current DODGE RAM 3500 SERIES DUALLY BOX
PART #13524**

Congratulations on your purchase of a high quality PUTCO product. Should you need any application or technical assistance feel free to call us at:
1-800-247-3974

Monday-Friday 8:00 a.m.- 5:00 p.m. (Central Standard Time)

Contact your PUTCO dealer for other quality accessories.

PUTCO Inc. - 216 West First Street - Story City, Iowa 50248

PLEASE READ ALL INSTRUCTIONS BEFORE BEGINNING INSTALLATION AND BE SURE TO CHECK TO SEE THAT ALL PARTS AND HARDWARE ARE INCLUDED.

Parts List		Bolt kit		Tools Needed for Installation	
Description	Qty	Description	Qty		
Box boards	2	1/4" x 1-1/4" SS Slot head screw (#726)	8	Electric Drill	
Flaps (#7432 & #7433)	2	1/4" x 3/4" Hex head bolts (#730)	26	3/16" and 1/4" Drill Bit	
End caps (7811)	2	1/4" Lock washer (#780)	34	3/8" Magnetic Socket Holder	
18" Mini trim (#7820)	3	1/4" Hex Nut (#790)	34	7/16" Wrench and Socket	
L-Bracket (#521)	2	1/4" x 1" Self drill & tap screws (#701)	18	Screwdriver (flat head)	
6" Flat strap (#510)	6			Vise grips or C-clamps	
18" 3-3/4" Flat braces (#10517)	2			Level	
18-1/2" Angle bracket (#554)	4			Tin snips	
14-3/4" Angle bracket (#553)	2				
1-1/2"x 1-1/2" Angle bracket 90 degree(#548)	2				
Foam Tape (#689)	1 Roll				

NOTE: Remove the protective plastic coating from the running boards and mud flaps. Trim the black vinyl tape on each end of the running boards, so that the tape edge is flush with the end of running board. The steps and figures shown are for the passenger side installation.

Step 1: Form the flap to conform to the wheel well opening. (SEE FIGURE 1). Bolt the mud flap to the rear of the running board using 1/4" x 1-1/4" SS slot head screws, lock washers, and hex nuts. (SEE FIGURE 1). Next apply the mini-trim (#7820) 18" ONLY along the outside edge of the flaps. (optional). (SEE FIGURE 3).

Step 2: Apply the foam tape along the back of the board so that it is flush with the top of the back lip. (SEE FIGURE 2).

Step 3: Attach the end cap (#7811) to the front of the running board using 1/4" x 1-1/4" SS slot head screws, lock washers, and hex nuts. (SEE FIGURE 3).

Step 4: Attach the 14-3/4" angle bracket (#553) to the weld-in that is 4-3/4" from the front of the running board, using 1/4" x 3/4" hex head bolts, lock washers and nuts. Attach the 18-1/2" angle bracket (#554) to the weld-in that is 25-1/2" from the front of the running board, using 1/4" x 3/4" hex head bolts, lock washers and nuts. Figure tighten only.(SEE FIGURE 3). Next bolt a 18" x 3-3/4" flat brace (#10517) to the middle of the 14-3/4" angle bracket, you will need to drill a hole so the both holes at the bottom of the flat brace can be used. Attach the other 18-1/2" angle bracket to the angle bracket at 25-1/2" from the front of the board(SEE FIGURE 3).

Step 5: Attach a 6" flat strap (#510) to the end of the 14-3/4" angle bracket. Use a 1/4" x 3/4" hex bolt, lock washer, and nut. Attach a 1-1/2" x 1-1/2" Angle bracket with 90degree bend to the end of the 6" flat strap. (SEE FIGURE 3).

Step 6: There are two factory screws in the wheel well opening of the vehicle that will be covered by the flap. Remove these screws before clamping the board and flap to the vehicle. DO NOT lose the screws as you will use them later.

Step 7: Now take the box board and clamp the flap to the wheel well opening. Clamp the 18"-3/4" flat brace and 18-1/2" angle bracket to the under body cross braces. (SEE FIGURE 3). Make sure the front of the box board matches up with the rear of the cab board, both in and out, and up and down positions.

Step 8: Once you have the front of the box in line with the cab, check and make sure the rear of the board is level with the cab. (NOTE: The best way to check this is to look down the front of the cab board by the flap, towards the rear of the box board). Make adjustments in and out or up and down until you have a perfect alignment.

Step 9: Once you have the box board aligned, mount both brackets to the under body cross brace using two 1/4" x 1" self drill and tap screws for each brace. (SEE FIGURE 3). Next attach 1-1/2" x 1-1/2" angle bracket (#548) to the frame using a 1/4" x 1" self drill and tap screws-NOTE: If needed, pre drill the hole then run the self drill and tap screws through the hole. (SEE FIGURE 3).

Step 10: Attach two 6" flat straps (#510) to the 18-1/2" angle bracket that runs vertically. Attach the other end of the top strap to the under body cross brace with a self tapping screw. Attach the other end of the bottom strap to the 18-1/2" angle bracket that runs horizontally. Recheck the alignment and tighten all the nuts and bolts(SEE FIGURE 3).

Step 11: Using the holes from the screws you removed in Step 6 as a guide drill matching holes in the mud flap. Reinstall the factory screws you removed earlier so that they secure the mud flap to the wheel well.

Note: PUTCO recommends applying a high quality automotive wax to maintain the original appearance on your new running boards. February 2003

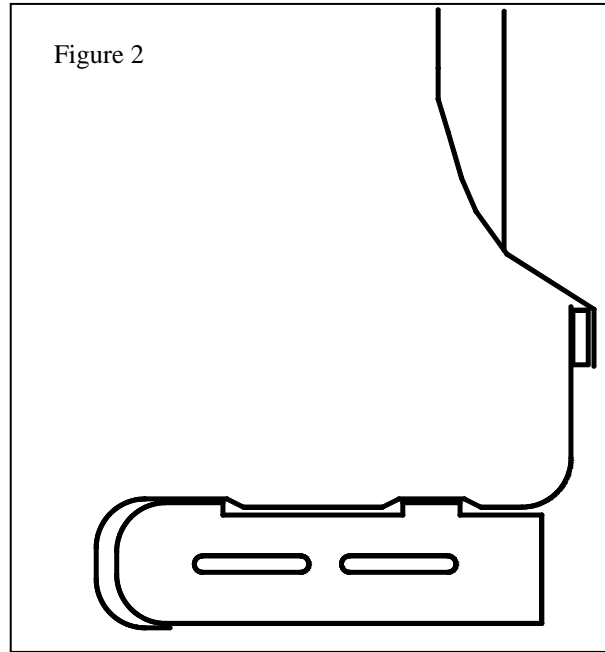
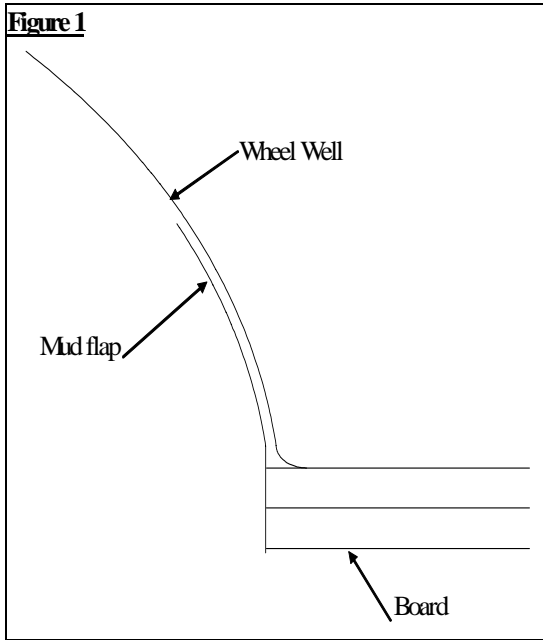
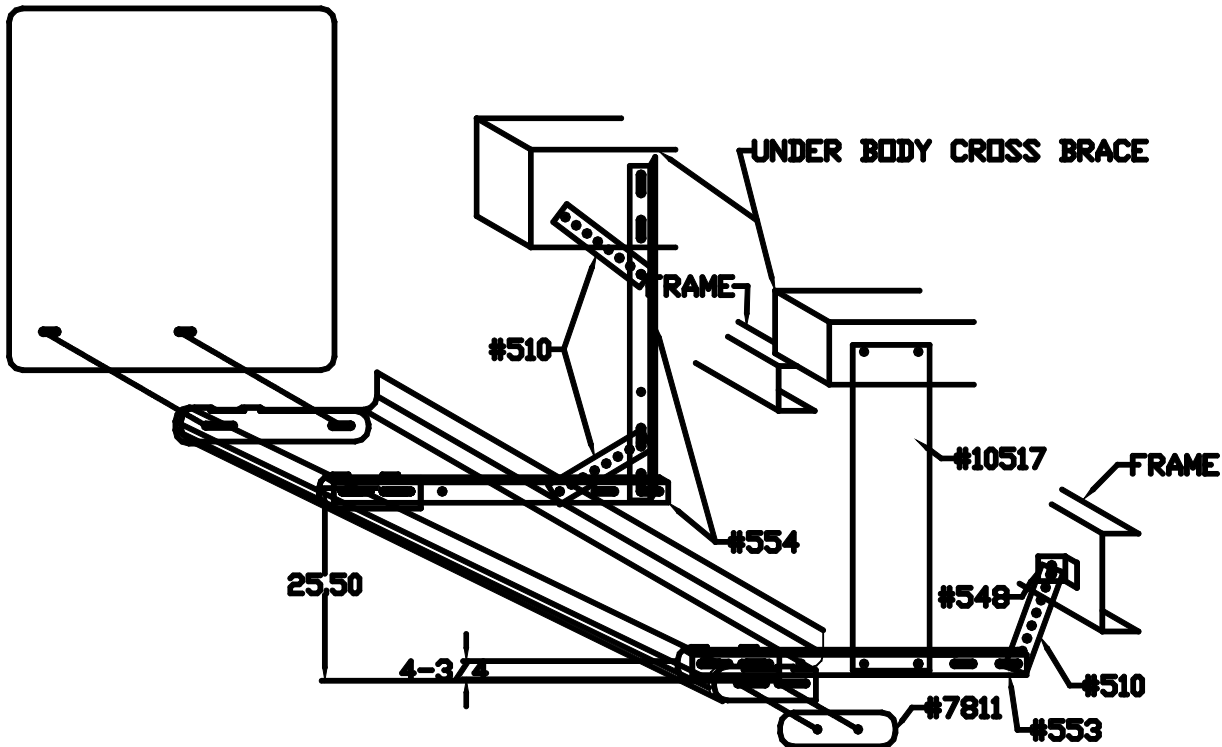

FIGURE 3



LIMITED WARRANTY

Putco guarantees it's Stainless Steel and Aluminum products against defects in workmanship and material for as long as you own your vehicle. Black products have a 90 day warranty on the painted surface. Any defects resulting from faulty material or workmanship will be warranted by Putco and repaired or replaced at our discretion. Putco assumes no extra labor costs. Damages caused by freight carriers, improper installation, misuse, collision, or neglect will not be warranted by Putco.