



**INSTALLATION INSTRUCTIONS FOR BOSS BARS #46137
2003-UP DODGE RAM QUAD CAB, DUALY BOX WHEEL TO WHEEL**

Congratulations on your purchase of a high quality PUTCO product.

Should you need any application or technical assistance feel free to call us at: 1-800-247-3974

Monday-Friday 8:00 a.m.- 5:00 p.m. (Central Standard Time)

Contact your PUTCO dealer for other quality accessories.

PUTCO Inc. - 216 West First Street - Story City, Iowa 50248

Please read all instructions before beginning installation and be sure to check to see that all parts and hardware are included.

Parts List	
Description	Qty
Front Driver Bracket (#1966)	1
Front Pass Bracket (#1967)	1
Rear Driver Bracket (#1968)	1
Rear Pass Bracket (#1969)	1
1/2" x 2" Hex head bolts (#00738)	4
1/2" Flat washer (#775)	4
1/2" Lock washer (#783)	4
Bolt Plate (#1965)	10
2" x 2" Square (#1964)	10
3/8" Flange Nut (#789)	10

Tools Needed for Installation
3/4" Socket
9/16" Socket

Note: Instructions and figures are for the Driver side.

Step 1: Remove the two front oval shaped rubber plugs and the last oval shaped rubber plug or tape from the inner wall of the rocker panel. (see figure 1)

Step 2: Place a 2" x 2" square (#1964) on to each of the bolt plates (#1965).

Step 3: Next put a bolt plate into each one of the oval shaped holes that you removed the plugs from. The 2" x 2" square will keep the bolt plate from falling through the hole during installation. (see figure 2)

Step 4: There are two square shaped holes in the floor of the vehicle. One at the front and one at rear, install a bolt plate in each of these holes. (see figure 1)

Step 5: Put the front and rear brackets into place so that the bolts on the bolt plates are sticking through the mounting holes. Secure into place using the 3/8" flange nuts. Finger tighten only. (see figure 1 & 2)

Step 6: Attach the boss bar to the brackets using a 1/2" x 2" Hex head bolt, flat washer, and lock washer at each end. (see figure 3)

Step 7: Tighten all nuts and bolts

Repeat steps 1 through 7 for passenger side

Note: PUTCO recommends applying a high quality automotive wax to maintain the original appearance on your new Boss Bars.

INSTRUCTION # IN46133-August 2002

LIMITED WARRANTY

Putco guarantees it's Stainless Steel and Aluminum products against defects in workmanship and material for as long as you own your vehicle. Black products have a 90 day warranty on the painted surface. Any defects resulting from faulty material or workmanship will be warranted by Putco and repaired or replaced at our discretion. Putco assumes no extra labor costs. Damages caused by freight carriers, improper installation, misuse, collision, or neglect will not be warranted by Putco.

FIGURE 1

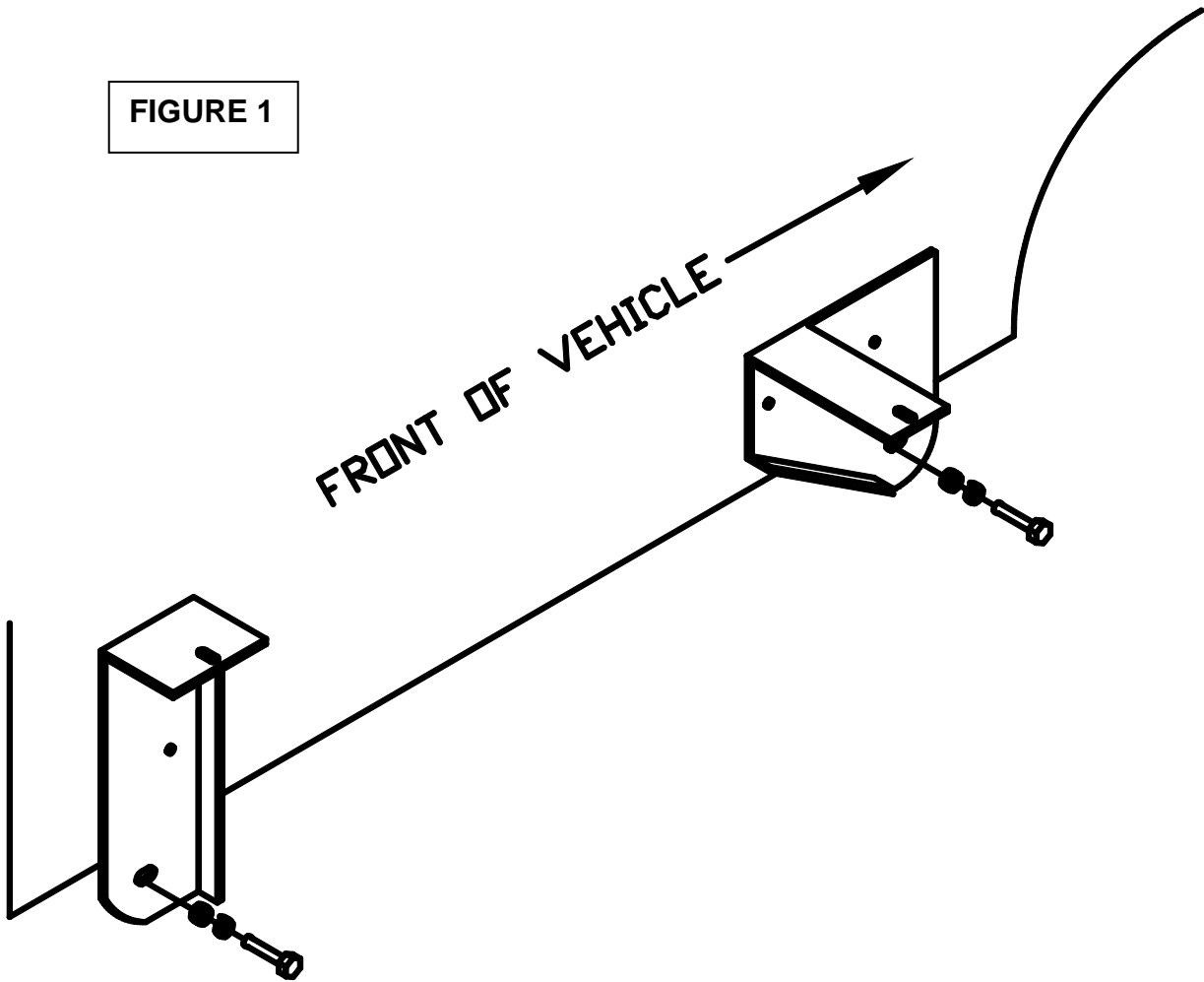

FIGURE 2

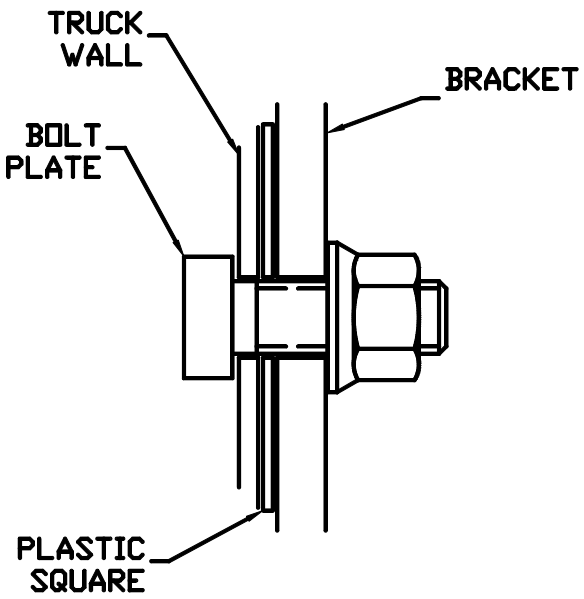

FIGURE 3

