



# INSTALLATION INSTRUCTIONS FOR BOSS BARS FOR 2002 HUMMER H2 WHEEL TO WHEEL BARS

Congratulations on your purchase of a high quality PUTCO product.

Should you need any application or technical assistance feel free to call us at: **1-800-247-3974**

**Monday-Friday 8:00 a.m.- 5:00 p.m. (Central Standard Time)**

**Contact your PUTCO dealer for other quality accessories.**

**PUTCO Inc. - 216 West First Street - Story City, Iowa 50248**

**Please read all instructions before beginning installation and be sure to check to see that all parts and hardware are included.**

Parts List	
Description	Qty
Boss Bar (Driver)	2
Boss Bar (Passenger)	2
Universal Rear Bracket (1907)	2
Universal Front Bracket (1980)	2
Universal Rear Support (1981)	2
Driver Front Support (1982)	1
Passenger Front Support (1983)	1
Bolt Plate (1965)	4
1 ½" x 1 ½" Rubber Pad (1908)	4
3/8" Nut	4
½" Hex Head Bolts (00738)	4
½" Flat Washer (775)	4
½" Lock Washer (783)	4

Tools Needed for Installation
19mm Socket
3/4" Wrench and Socket
Torque Wrench

- Step 1:** Remove the existing body mount bolts at the front and the rear of the cab using a 19mm socket and ratchet.
- Step 2:** Install the front and rear brackets with the metric bolts you removed in Step 1. Leave loose at this time.  
**NOTE:** The front bracket is shorter than the rear bracket.
- Step 3:** Locate the hole on the bottom surface of the frame. It is located to the rear of the front mounting bracket.
- Step 4:** Slide the bolt plate into the hole so that it rests with the bolt sticking out of the frame.
- Step 5:** Fasten the front support bracket to the bolt protruding through the hole in the bottom of the frame, the longest side attaches to the frame. Orient the support strap so that the shorter side faces the main bracket.
- Step 6:** Thread one 3/8" nut onto the bolt sticking out from the frame.
- Step 7:** Place a rubber pad on a bolt plate and insert the bolt plate into the hole on the frame directly across from the rear mounting bracket.
- Step 8:** Place the rear support strap between the frame and the rear mounting bracket so that the bolt on the bolt plate installed in Step 7 sticks through one hole on the support strap and the other hole should line up with the hole on the mounting bracket.
- Step 9:** Place a lock washer (783) on a ½" hex head bolt (00738) and place the bolt through the hole in the support strap and the mounting bracket.
- Step 10:** Place a flat washer (775) on the bolt sticking out from the mounting bracket and start to thread the bolt into the weld insert on the corresponding end of the Boss Bar.
- Step 11:** Repeat Step 10 for the rear.
- Step 12:** Once everything is in place and all the bolts have been started, tighten all the bolts until secure.
- Step 13:** Once everything is has been tightened, torque the cab mount bolts to 65 FT-LBS.
- Step 14:** Repeat Steps for the other side.

---

**Note:** PUTCO recommends applying a high quality automotive wax to maintain the original appearance on your new Boss Bars.

---



# INSTALLATION INSTRUCTIONS FOR BOSS BARS FOR 2002 HUMMER H2 WHEEL TO WHEEL BARS

**NOTE:** THE DIAGRAM IS FOR REPRESENTATION PURPOSES ONLY. SOME FEATURES MAY NOT ACTUALLY BE WHERE DIAGRAM SHOWS.

**Figure 1**

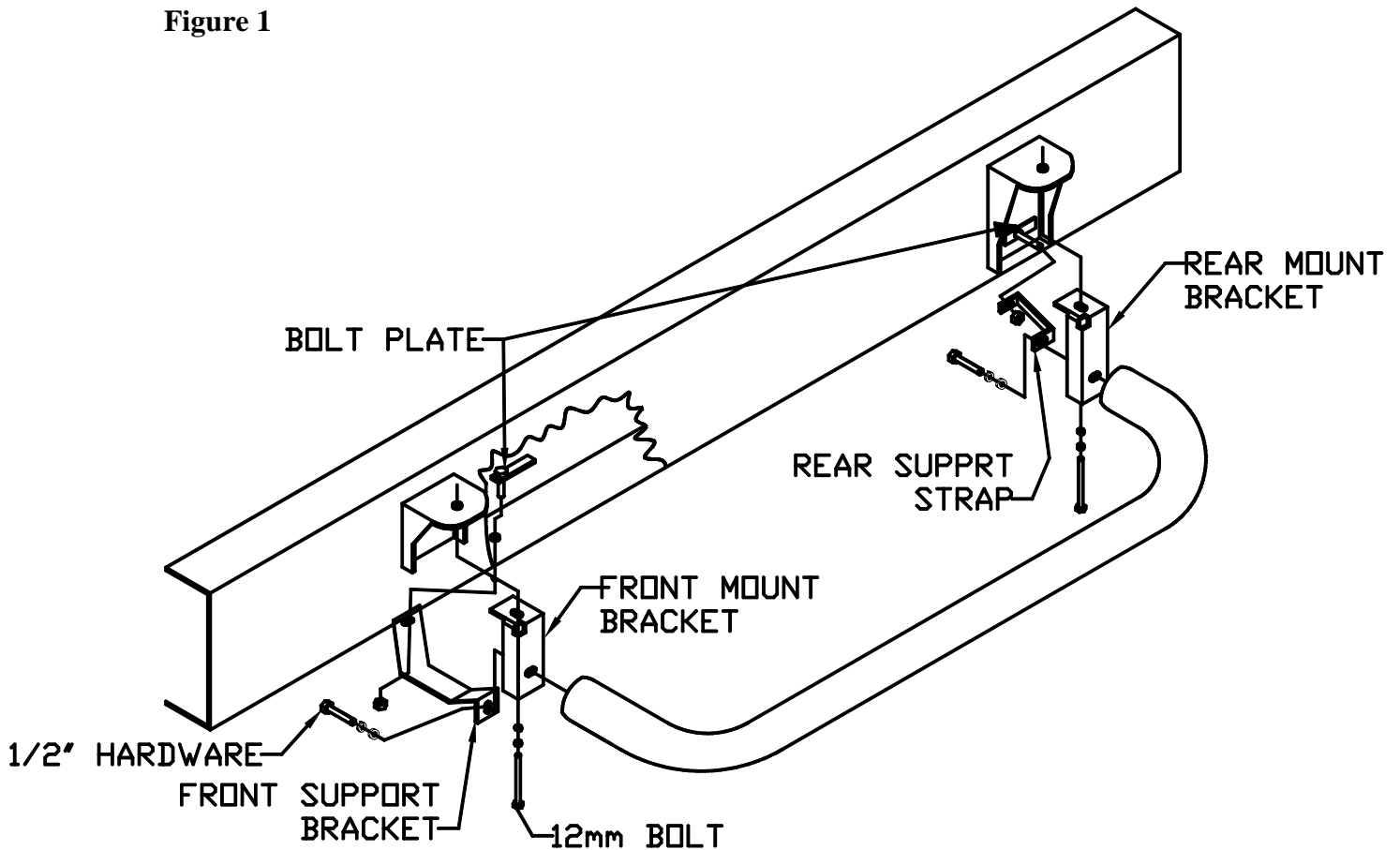

## LIMITED WARRANTY

Putco guarantees it's Stainless Steel and Aluminum products against defects in workmanship and material for as long as you own your vehicle. Black products have a 90 day warranty on the painted surface. Any defects resulting from faulty material or workmanship will be warranted by Putco and repaired or replaced at our discretion. Putco assumes no extra labor costs. Damages caused by freight carriers, improper installation, misuse, collision, or neglect will not be warranted by Putco.