



**2001 CHEVY / GMC SILVERADO/SIERRA 2500-3500 HEAVY DUTY
PART #61123 CREW CAB**

Congratulations on your purchase of a high quality PUTCO product. Should you need any application or technical assistance feel free to call us at:

1-800-247-3974

Monday-Friday 8:00 a.m.- 5:00 p.m. (Central Standard Time)

Contact your PUTCO dealer for other quality accessories.

PUTCO Inc. - 216 West First Street - Story City, Iowa 50248

PLEASE READ ALL INSTRUCTIONS BEFORE BEGINNING INSTALLATION AND BE SURE TO CHECK TO SEE THAT ALL PARTS AND HARDWARE ARE INCLUDED.

Parts List

Description	Qty
Running boards	2
Flaps (#6422 & #6423)	2
Endcaps (#7814)	2
18" Mini-Trim (#7820)	2
94" Vinyl Foam Tape (#698)	2
L-shaped bracket (#10513)	4
10" Bent bracket (#10512)	2
14-3/4" Angle bracket (#553)	2
6" Flat brace (#510)	2
1/4" x 1-1/4" SS Slot head screw (#726)	18
1/4" x 3/4" Hex head bolts (#730)	14
1/4" Flange nut (#791)	32
1/4" x 3/4" Self drill & tap screws (#701)	14

Tools Needed for Installation

Electric Drill
1/4" Drill Bit
3/8" Magnetic Drive Socket
7/16" Wrench and Socket
Screwdriver (flat head)
Vise grips
Level

NOTE: Remove the protective plastic coating from the running boards and mud flaps. Trim the black vinyl tape on the running boards, so that the tape edge is flush with the end of the running board. The steps and figures shown are for the passenger side installation.

Step 1: Form the mud flaps to conform to the wheel well opening. Bolt the mud flap to the front and an end cap (#7814) to the rear of the running board using 1/4" x 1-1/4" SS slot head screws and flange nuts. (SEE FIGURE 3) Next apply mini-trim (#7820) only along the edge of the mud flap (optional). (SEE FIGURE 3)

Step 2: Apply foam tape (#697) along the top of the back lip of the running board. (SEE FIGURE 1)

Step 3: Using three C-clamps or vice grips, clamp running board to rocker panel. Make sure the mud flap is all the way back to the front wheel well opening.

Step 4: Drill three 1/4" holes through the rocker panel lip. Install 1/4" x 1-1/4" SS slot head bolts, and flange nuts. (SEE FIGURE 1)

Step 5: Make sure the board is level outward from the vehicle and level along the vehicle. Attach the mud flaps to the vehicle using three 1/4" self drill and tap screws per flap.

Step 6: Next bolt the L-shaped brace (#10513) to the weld-ins at 26-1/2" and 70-1/2" using 1/4" x 3/4" hex head bolts and flange nuts. Recheck the boards alignment, then attach the L-shaped braces to the under body cross brace using two 1/4" x 3/4" self drill and tap screws (#701).

Step 7: Attach the 14-3/4" angle bracket (#553) to the rear weld-in using 1/4" flange nuts, leave the existing flange nuts in place. Next attach the 10" bent brace (#10512) to the angle bracket using 1/4" x 3/4" hex head bolts and flange nuts. Using the holes at the top of the bent brace as a guide drill two 1/4" holes in to the rear of the cab. Attach the brace to the rear of the cab using two 1/4" x 1-1/4" SS slot head bolts and flange nuts. (put the nuts on the cab side of the hole.)

Step 8: Attach a 6" flat brace (#510) to the end of the 14-3/4" angle bracket using a 1/4" x 3/4" hex head bolt and flange nut. Drill a 1/4" hole into the body mount and attach the flat brace to the body mount using a hex head bolt and flange nut.

Note: PUTCO recommends applying a high quality automotive wax to maintain the original appearance on your new running boards.

INSTRUCTION SHEET FOR IN61123-NOVEMBER 2000



2001 CHEVY / GMC SILVERADO/SIERRA 2500-3500 HEAVY DUTY

PART #61123 CREW CAB

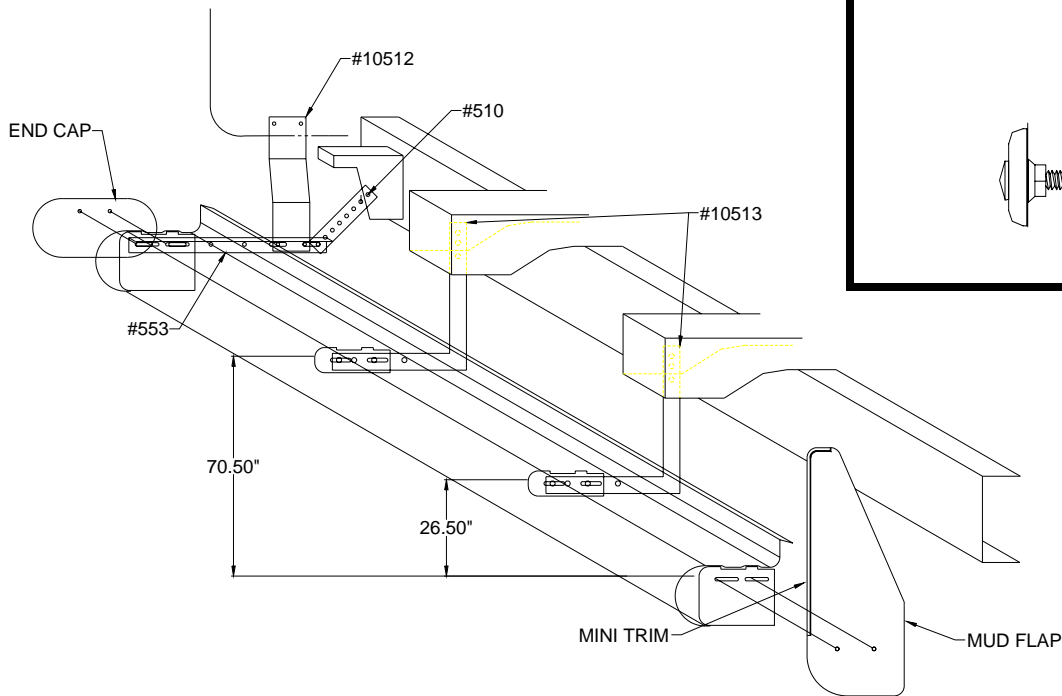
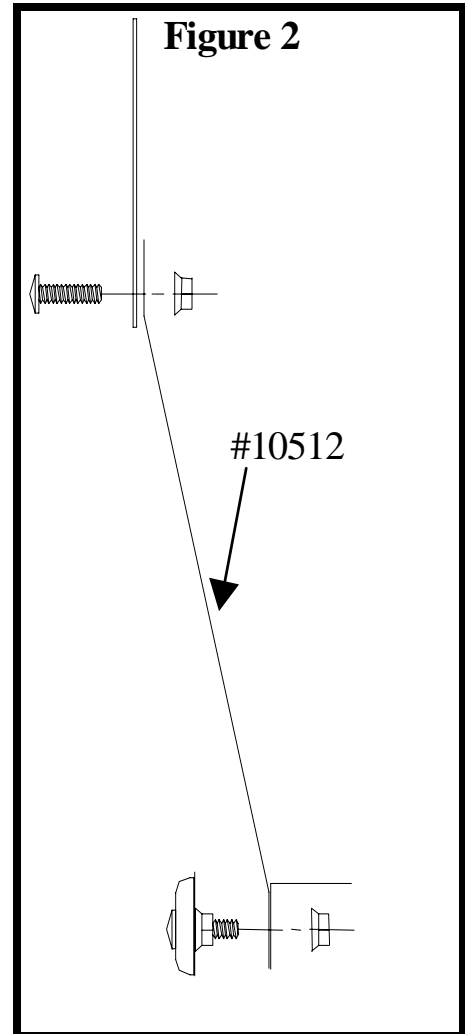
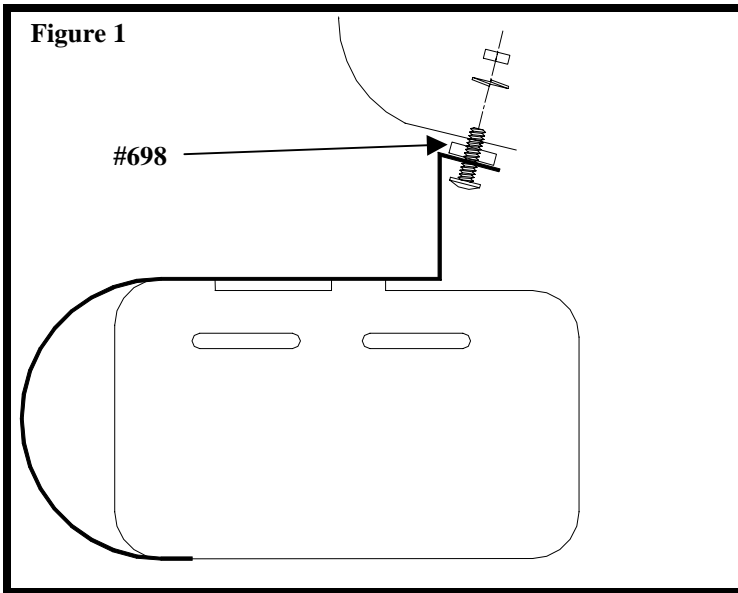

LIMITED WARRANTY

Putco guarantees its Stainless Steel and Aluminum products against defects in workmanship and material for as long as you own your vehicle. Black products have a 90 day warranty on the painted surface. Any defects resulting from faulty material or workmanship will be warranted by Putco and repaired or replaced at our discretion. Putco assumes no extra labor costs. Damages caused by freight carriers, improper installation, misuse, collision, or neglect will not be warranted by Putco.