



**1992-UP CHEVY / GMC 1500-3500 CK SERIES INSTALLATION SHEET
PART #61124 (EXTENDED CAB)**

Congratulations on your purchase of a high quality PUTCO product. Should you need any application or technical assistance feel free to call us at:
1-800-247-3974

Monday-Friday 8:00 a.m. - 5:00 p.m. (Central Standard Time)
Contact your PUTCO dealer for other quality accessories.
PUTCO Inc. - 216 West First Street - Story City, Iowa 50248

PLEASE READ ALL INSTRUCTIONS BEFORE BEGINNING INSTALLATION AND BE SURE TO CHECK TO SEE THAT ALL PARTS AND HARDWARE ARE INCLUDED.

Parts List	
Description	Qty
Driver board (#6082)	1
Passenger board (#6083)	1
Flaps (#6422 & #6423)	2
1/4" x 1-1/4" SS Slot head screw (#726)	22
1/4" x 3/4" Hex head bolts (#730)	14
1/4" Hex nut (#790)	36
1/4" Lock washer (#780)	36
1/4" x 1" Self drill & tap screws (#701)	8
18" Mini-Trim (#7820)	2
Endcaps(#7814)	2
80" Vinyl Foam tape (#697)	2
14-3/4" Angle bracket (#553)	2
Bent brace (#517)	2
Flat bracket (#533)	2

Tools Needed for Installation
Electric Drill
1/4" Drill Bit
3/8" Magnetic Drive Socket
7/16" Wrench and Socket
Screwdriver
Level
Vise Grips

NOTE: Remove the protective plastic coating from the running boards and mud flaps. Trim the black vinyl tape on the running boards, so that the tape edge is flush with the end of the running board. The steps and figures shown are for the passenger side installation.

Step 1: Form the mud flaps to conform to the wheel well opening. **(SEE FIGURE 1)** Bolt the stainless steel mud flap to the front of the running board using two 1/4" x 1 -1/4" SS slot head screws, lock washers, and nuts. Next apply mini -trim **(#7820)** only along the edge of the mud flap **(optional)**. **(SEE FIGURE 3)**

Step 2: Apply foam tape along back lip of running board. **(SEE FIGURE 2)**

Step 3: Using three C-clamps or vise grips, clamp the running board to the rocker panel and the mud flap to the wheel well opening. Make sure the running board is all the way back to the front of the wheel well opening.

Step 4: Drill four 1/4" holes through the rocker panel lip. Install 1/4" x 1 -1/4" SS slot head screws, lock washers, and nuts. **(SEE FIGURE 2)**

Step 5: Make sure the board is level outward from the vehicle and level along the vehicle. Attach the mud flaps to the vehicle using three 1/4" self drill and tap screws per flap.

Step 6: Bolt an end cap (#7814) and 12 -1/2" angle bracket **(#553)** to the rear of the running board, using 1/4" x 1 -1/4" SS slot head screws, lock washers, and nuts. Bolt a 4 -1/4" x 9-3/4" flat bracket **(#533)** to the **(#553)** angle bracket. **(SEE FIGURE 4)** The other end of the **(#533)** flat bracket bolts to the rear of the cab, you will have to drill three 1/4" holes in the lower rear cab lip. Use 1/4" x 1 -1/4" SS slot head screws, lock washers, and nuts. **(SEE FIGURE 4)**

Step 7: Bolt a 8" angle bracket **(#552)** to the center braces using 1/4" x 3/4" hex head bolts, lock washers, and nuts. Now bolt a **(#517)** bent brace to the 8" angle bracket **(#552)**, using 1-1/4" x 3/4" hex head bolts, lock washers, and nuts. The other end of the bent brace **(#517)** with a 10mm hole goes to the existing seat mounting bolt, Use the 10mm nuts that are included.

Note: PUTCO recommends applying a high quality automotive wax to maintain the original appearance on your new running boards.

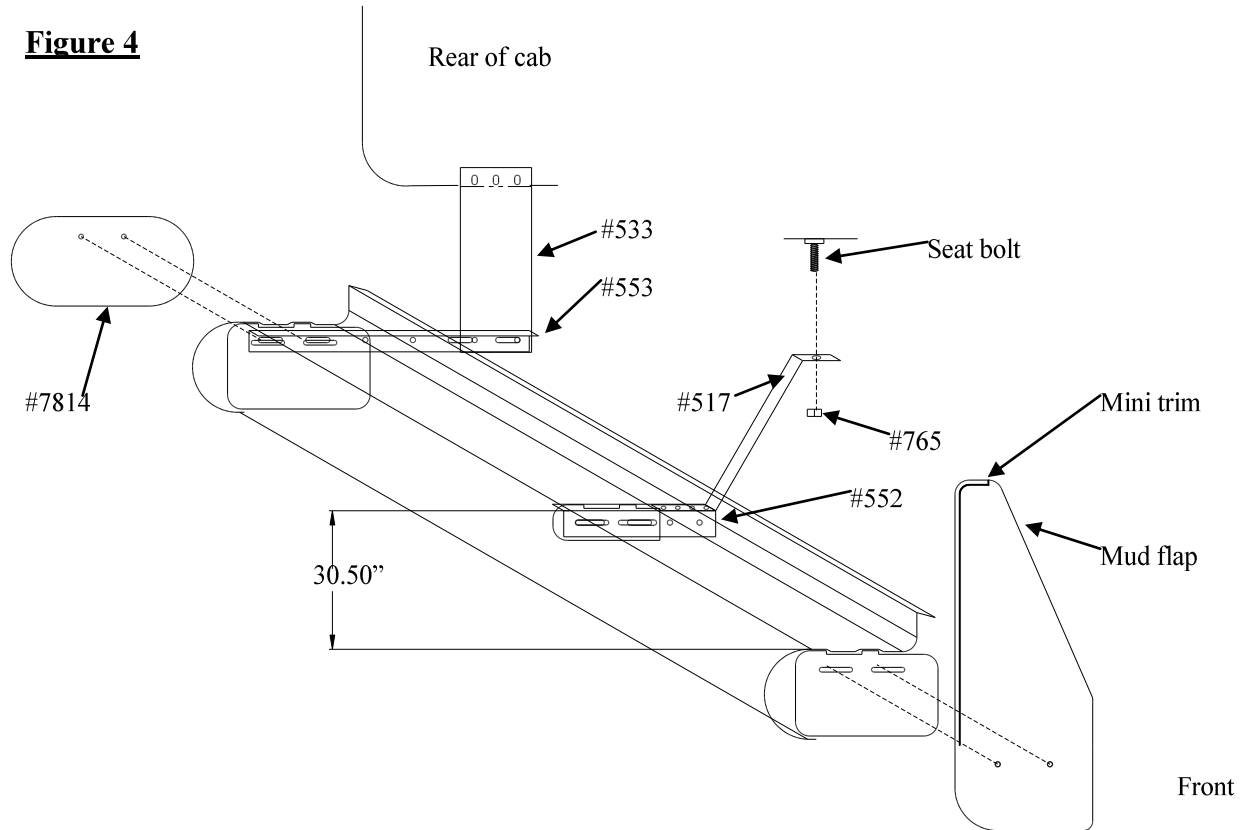
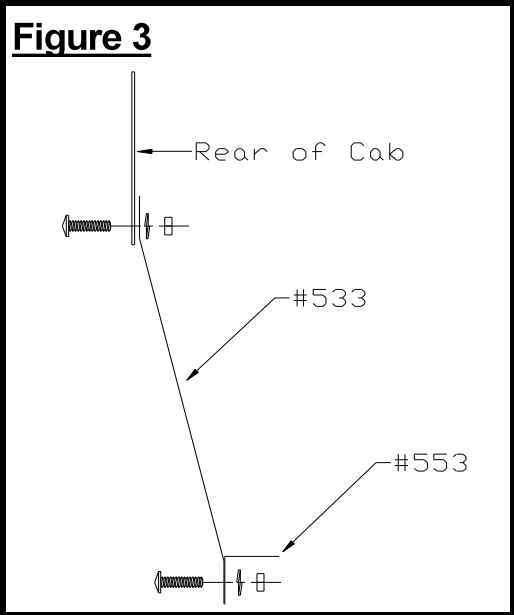
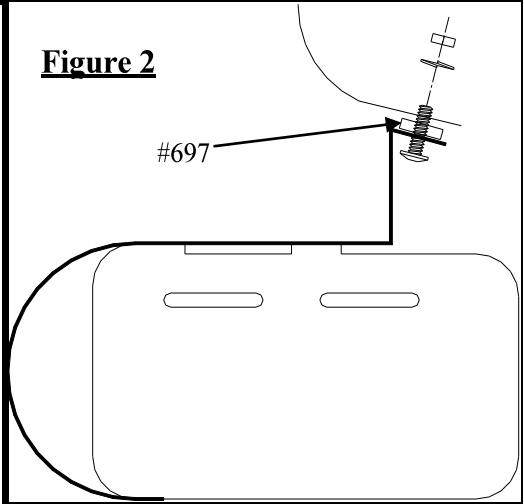
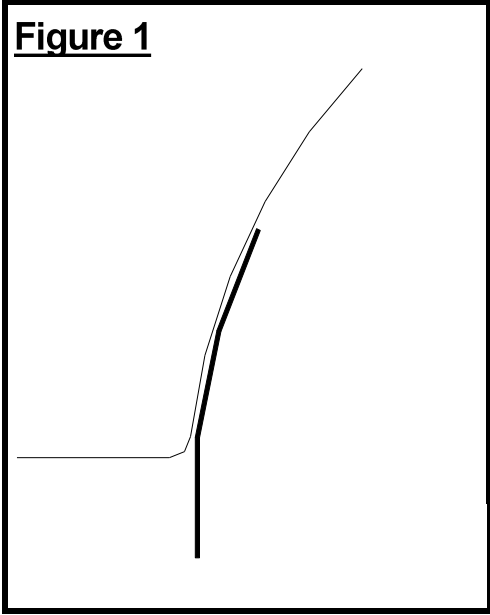

LIMITED WARRANTY

Putco guarantees its Stainless Steel and Aluminum products against defects in workmanship and material for as long as you own your vehicle. Black products have a 90 day warranty on the painted surface. Any defects resulting from faulty material or workmanship will be warranted by Putco and repaired or replaced at our discretion. Putco assumes no extra labor costs. Damages caused by freight carriers, improper installation, misuse, collision, or neglect will not be warranted by Putco.