



**1999-2000 FORD SUPER DUTY PICKUP (BOSS BOARDS)
PART #62129 & 62135 (SUPER CAB & CREW CAB)**

Congratulations on your purchase of a high quality PUTCO product. Should you need any application or technical assistance feel free to call us at:
1-800-247-3974

Monday-Friday 8:00 a.m.- 5:00 p.m. (Central Standard Time)

Contact your PUTCO dealer for other quality accessories.

PUTCO Inc. - 216 West First Street - Story City, Iowa 50248

PLEASE READ ALL INSTRUCTIONS BEFORE BEGINNING INSTALLATION AND BE SURE TO CHECK TO SEE THAT ALL PARTS AND HARDWARE ARE INCLUDED.

Parts List

<u>Description</u>	<u>Qty</u>
Running boards	2
Flaps (#6422 & #6423)	2
18" Mini-Trim (#7820)	2
Endcaps (#7814)	2
Driver side bracket (#09332)	3
Passenger side bracket (#09333)	3
1/4" x 1-1/4" SS Slot head screw (#726)	8
1/4" x 3/4" Hex head bolts (#730)	12
1/4" Flange nut (#791)	20
1/4" x 3/4" Self drill and tap screw (#701)	6
5/16" x 1" Hex head bolts (#735)	6
5/16" Flange nuts (#797)	6
Metric U-nut (#00703)	6
8mm Bolt (#00704)	6
5/16" Flat washer (#771)	6
Foam tape (#678)	1 Roll
Lip seal (#7828)	1/2 Foot

Tools Needed for Installation

- Power Drill
- 3/8 Magnetic drive socket
- Flat head screw driver
- 1/2" Wrench and Socket
- 13mm Socket
- 7/16" Wrench and Socket
- Vise Grips or C-clamps
- Level

NOTE: Remove the protective plastic coating from the running boards and mud flaps. The steps and figures shown are for the passenger side installation.

- Step 1:** Form the mud flaps to conform to the wheel well opening. **(SEE FIGURE 1)** Bolt the stainless steel mud flap to the front of the board using 1/4" x 1-1/4" SS slot head screws and flange nuts. Next apply mini-trim **(#7820)** only along the outside edge of the mud flap (optional). **(SEE FIGURES 1 & 4)**
- Step 2:** Attach an end cap **(#7814-driver/7814-passenger)** to the rear of the board using 1/4" x 1-1/4" SS slot head screws and flange nuts. Now run a strip of foam tape along the top backside of the running board, and flush with the top edge of the board. **(SEE FIGURE 4)**
- Step 3:** Using the weld-ins on the board as a guide locate the existing holes in the rocker panel, attach the passenger side brackets **(SEE FIGURE 2)** to these holes using a 5/16" x 1" Hex head bolt, flat washer, and flange nut on each bracket. Finger tighten. **(SEE FIGURE 3)**
- Step 4:** The upper hole on the bracket will attach to an existing hole straight up from the first hole. To attach the bracket to this hole you must first install a u-nut over existing the hole **(SEE FIGURE 3)**. Next run an 8mm bolt through the bracket and u-nut. Finger tighten.
- Step 5:** Attach the board to the brackets using 1/4" x 3/4" hex head bolts and flange nuts. Leave loose.
- Step 6:** Make sure the flap is flush against the wheel well and tighten the bracket bolts, check the board for alignment. Then tighten the bolts that attach the board to the brackets, and recheck the alignment of the board. **(SEE FIGURE 4)**
- Step 7:** Level the front of the running board, using three self drill and tap screws attach to mud flap to the fender well.
- Note:** Lip seal has been included to cover any gap between the front notch and the bottom of the truck.
- Step 8:** Repeat the above steps for the driver side.

Note: PUTCO recommends applying a high quality automotive wax to maintain the original appearance on your new running boards.



PART #62129 & 62135 (SUPER CAB & CREW CAB)

Figure 1

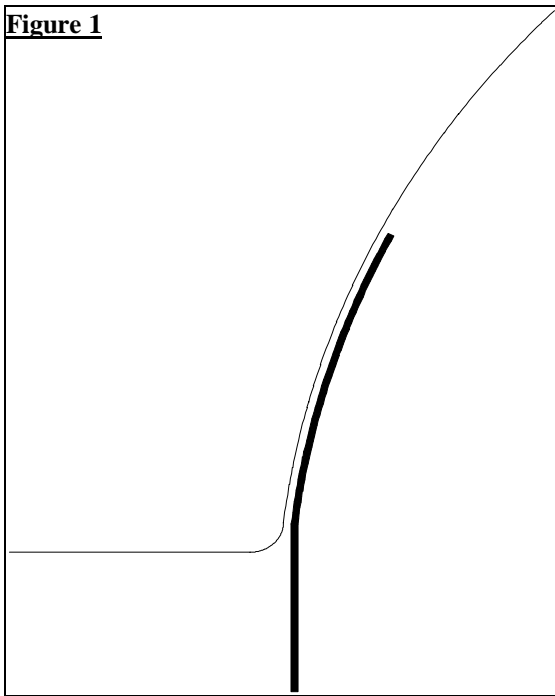

Figure 2

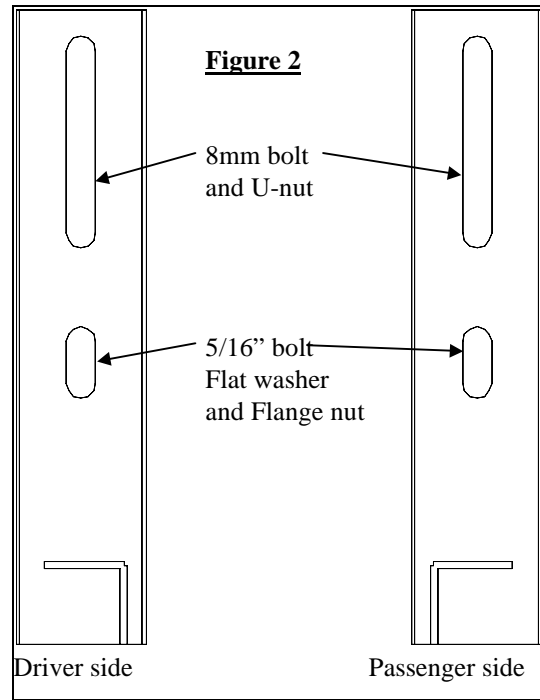

Figure 3

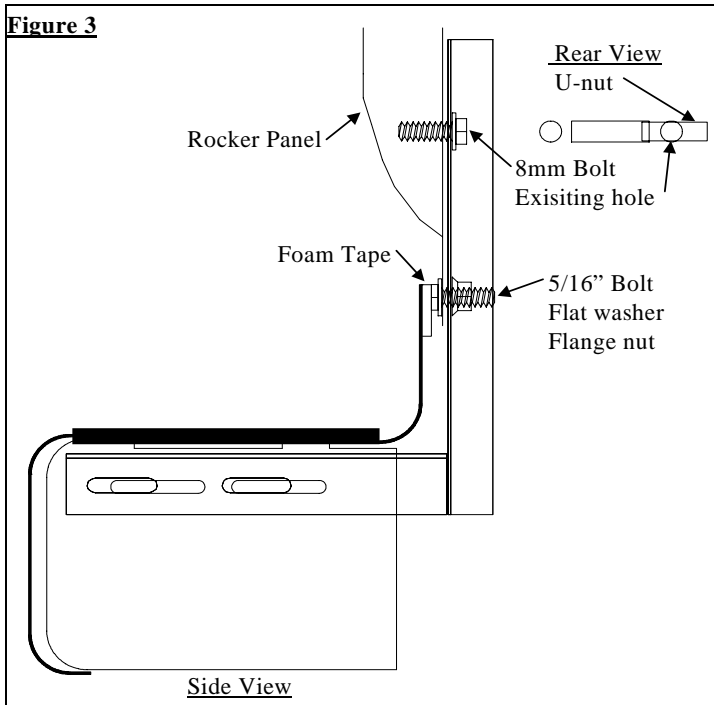
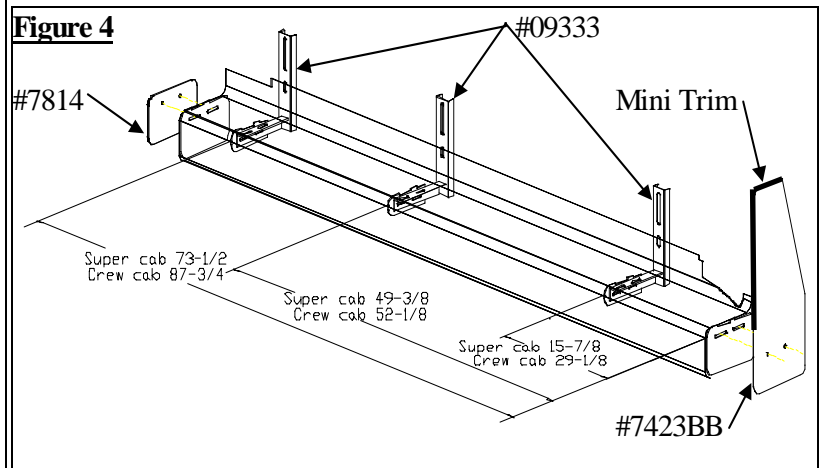

Figure 4



LIFETIME WARRANTY

Putco guarantees it's Stainless Steel and Aluminum products against defects in workmanship and material for as long as you own your vehicle. Black products have a 90-day warranty on the painted surface. Any defects resulting from faulty material or workmanship will be warranted by Putco and repaired or replaced at our discretion. Putco assumes no extra labor costs. Damages caused by freight carriers, improper installation, misuse, collision, or neglect will not be warranted by Putco.