



**1994-UP DODGE RAM INSTALLATION SHEET
PART #63522(DUALLY LONG BOX)**

Congratulations on your purchase of a high quality PUTCO product. Should you need any application or technical assistance feel free to call us at:
1-800-247-3974

Monday-Friday 8:00 a.m.- 5:00 p.m. (Central Standard Time)

Contact your PUTCO dealer for other quality accessories.

PUTCO Inc. - 216 West First Street - Story City, Iowa 50248

PLEASE READ ALL INSTRUCTIONS BEFORE BEGINNING INSTALLATION AND BE SURE TO CHECK TO SEE THAT ALL PARTS AND HARDWARE ARE INCLUDED.

Parts List	
Description	Qty
Boss boards	2
Flaps (#6480 & 6481)	2
1/4" x 1-1/4" SS Slot head screw (#726)	22
1/4" x 3/4" Hex head bolts (#730)	34
1/4" Hex nut (#790)	56
1/4" Lock washer (#780)	56
1/4" x 1" Self drill & tap screws (#701)	12
18" Mini-Trim (#7820)	2
Endcaps(#7814)	2
18-1/2" Angle bracket (#554)	4
12" Channel (#556)	2
9" Flat brace (#530)	4
16" Flat brace (#514)	4

Tools Needed for Installation
Electric Drill
1/4" Drill Bit
Screwdriver
Level
Vise Grips
3/8" Magnetic Drive Socket

NOTE: Remove the protective plastic coating from the box boards and mud flaps..

Step 1: Form the stainless steel mud flaps to conform to the wheel well opening. **(SEE FIGURE 1)** Bolt the stainless steel mud flap to the rear of the box board using two 1/4" x 1-1/4" SS slot head screws, lock washers, and nuts. Next, apply mini-trim **(#7820)** only along the edge of the mud flap (optional). **(SEE FIGURE 3)**

Step 2: There is a driver and passenger box board, the front bracket is 6" from the front edge. Bolt an end cap to the front edge of each box board with a 1/4" x 1-1/4" SS slot head screws, lock washers, and nuts. There is also a driver and passenger side end cap. **(SEE FIGURE 3)**

Step 3: Using two C-clamps or vise grips, clamp the 12" channel **(#556)** to the rocker panel, making sure the box board will line up with the front of the cab board. Drill two 1/4" holes through the rocker panel. Install 1/4" x 3/4" hex head bolts, lock washers, and nuts. **(SEE FIGURE 2 & 3)**

Step 4: Clamp the box board to the channel and mud flap to the wheel well flange. Make sure the box board is as far forward as possible. Drill two 1/4" holes through the box board and channel. Install 1/4" x 1-1/4" SS slot head screws, lock washers, and nuts. **(SEE FIGURE 2)**

Step 5: Make sure the box board is level outward from the vehicle. Bolt the 18-1/2" angle bracket **(#554)** to the brace on the box board that is located at 6" and 18" from the front of the box board. Attach the 9" flat brace **(#530)** to the 18-1/2" angle bracket **(#554)**, the other end attaches to the box mount on the inside of the frame, by drilling two 1/4" holes. This will eliminate movement. Bolt the two 16" flat braces **(#514)** to the 18-1/2" angle bracket **(#554)** on the brace located at 6". Install to the floor beam using 1/4" self drill and tap screws. **(SEE FIGURE 3)**

Step 6: Bolt a 9" flat brace **(#530)** to the 18-1/2" angle bracket located 18" from the front of the box. **(SEE FIGURE 3)** Now attach the other end of the box mount on the side of the frame. By drilling two 1/4" holes in the side of the box mount.

Step 7: Make sure the front of the box board is level outward from the vehicle. Install three 1/4" self drill and tap bolts. Install two 1/4" x 1-1/4" SS slot head screws, lock washers, and nuts through the mud flap and box board. Lastly, attach the mud flap to the inner fender using existing holes and 1/4" x 1-1/4" SS slot head screws, lock washers, and nuts. **(SEE FIGURE 3)**

Note: PUTCO recommends applying a high quality automotive wax to maintain the original appearance on your new running boards.

INSTRUCTION SHEET FOR IN63522 -JANUARY 1999



1994-UP DODGE RAM INSTALLATION SHEET

PART #63522 (DUALY LONG BOX)

Figure 1

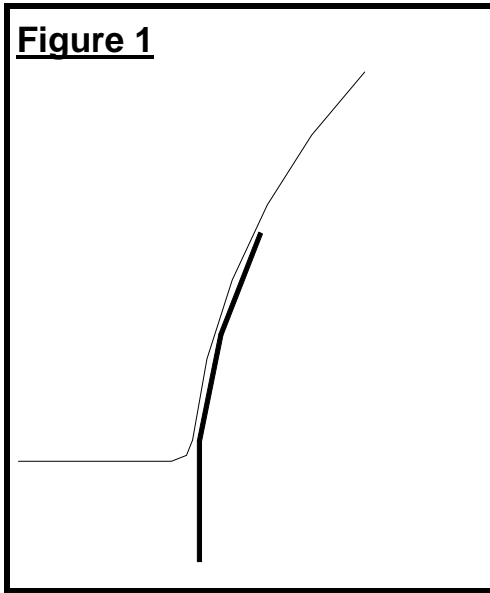

Figure 2

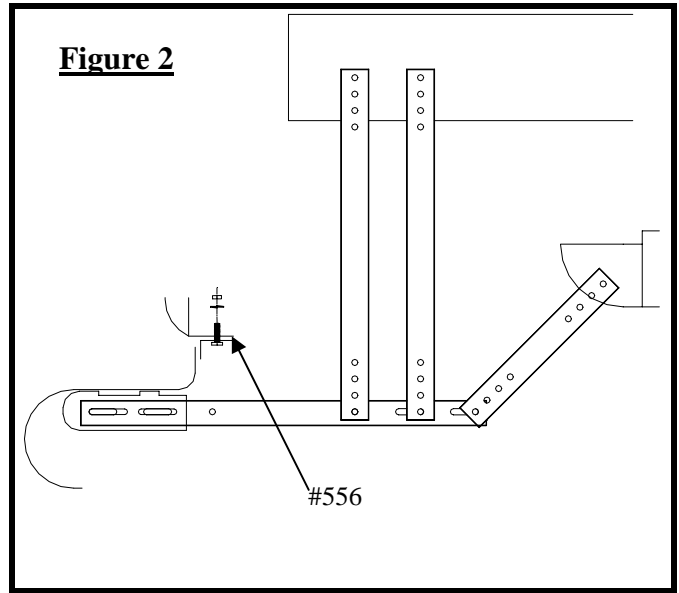
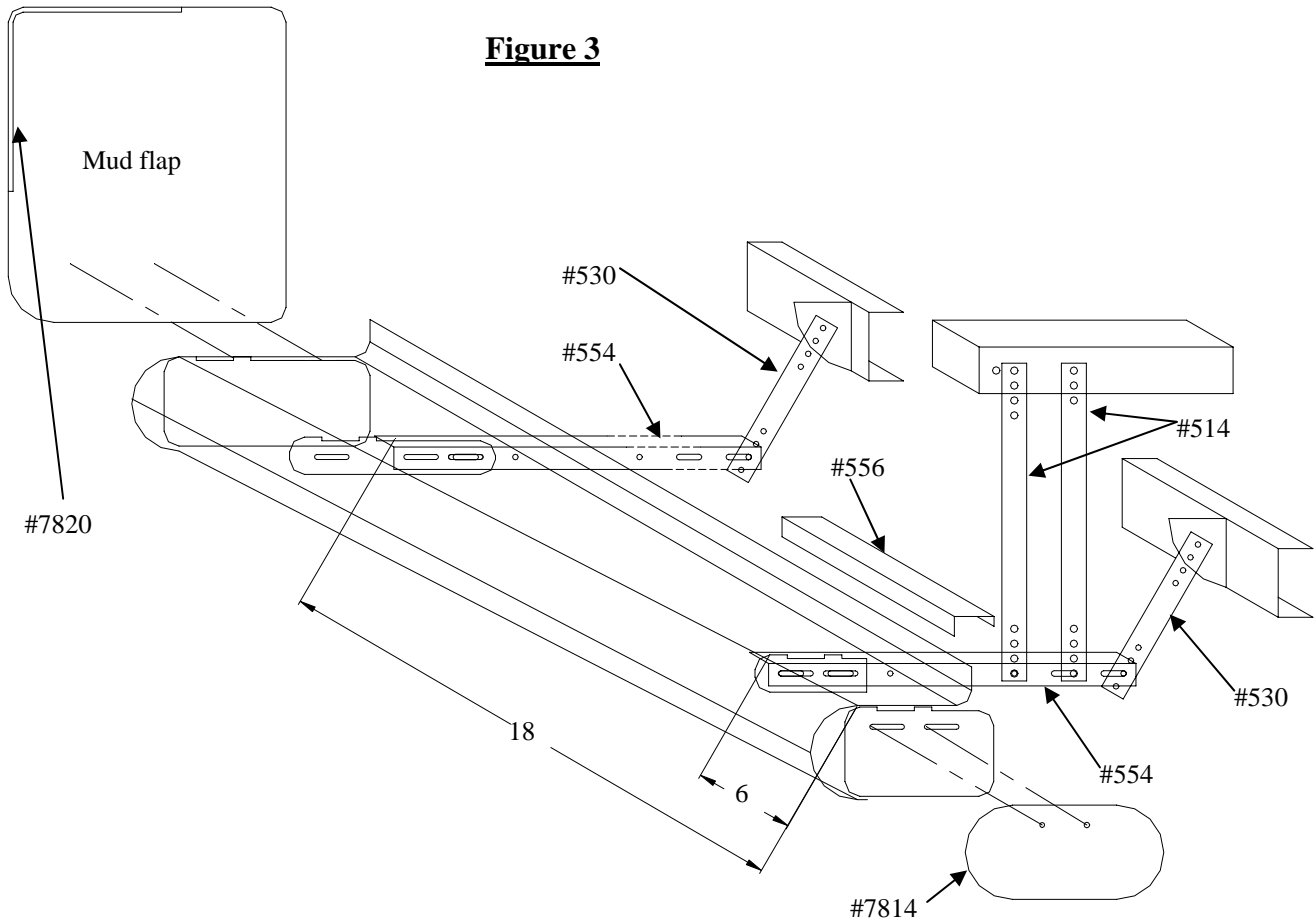

Figure 3



LIMITED WARRANTY

Putco guarantees its Stainless Steel and Aluminum products against defects in workmanship and material for as long as you own your vehicle. Black products have a 90 day warranty on the painted surface. Any defects resulting from faulty material or workmanship will be warranted by Putco and repaired or replaced at our discretion. Putco assumes no extra labor costs. Damages caused by freight carriers, improper installation, misuse, collision, or neglect will not be warranted by Putco.